



TAMIZ
Detalles de fabricación

TAMIZ
Fabrication details

ESQUEMA MONTAJE CORREDERA CON CARRIL COR-2427

SLIDING ASSEMBLY DIAGRAM WITH RAIL COR-2427

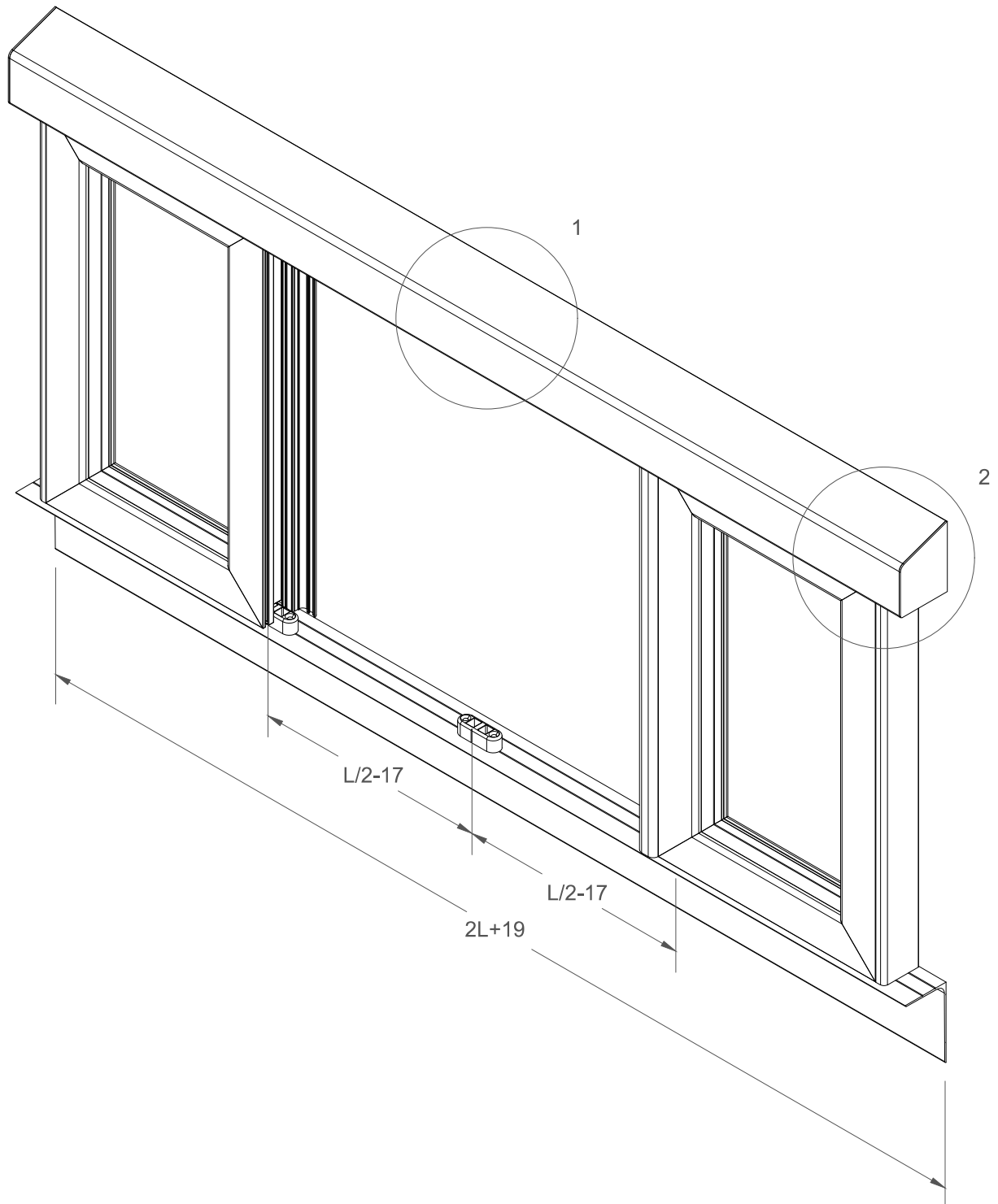

ESQUEMA MONTAJE CORREDERA CON CARRIL COR-2427
SLIDING ASSEMBLY DIAGRAM WITH RAIL COR-2427

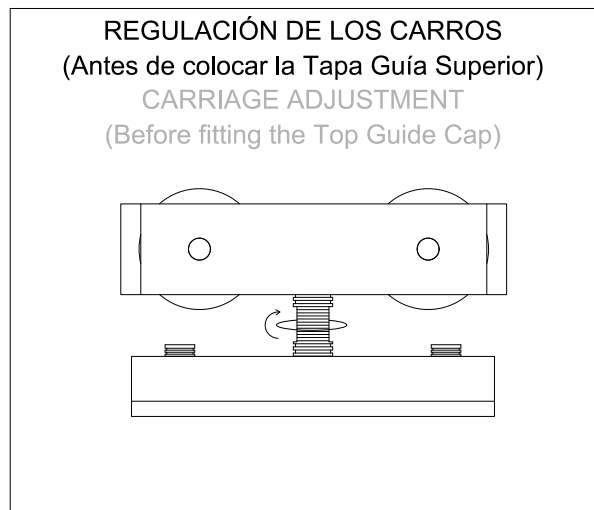
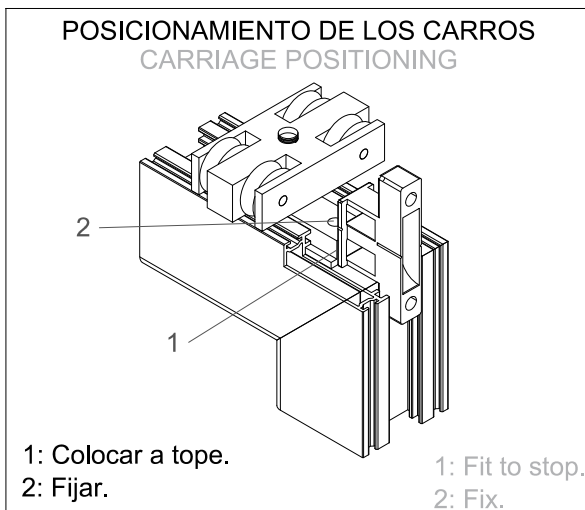
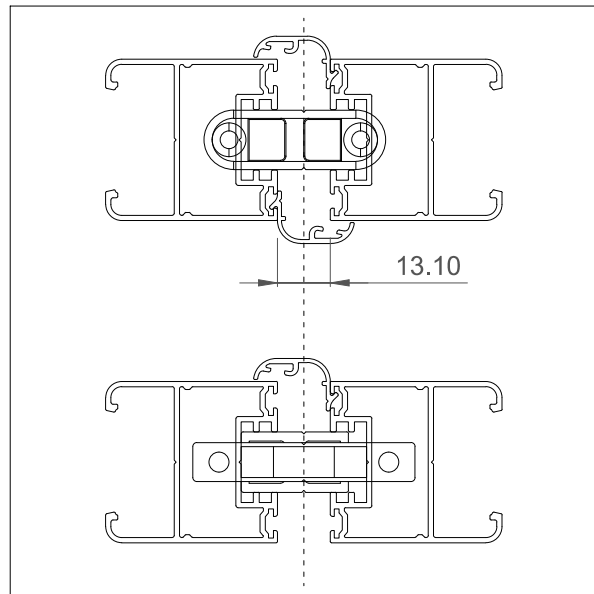
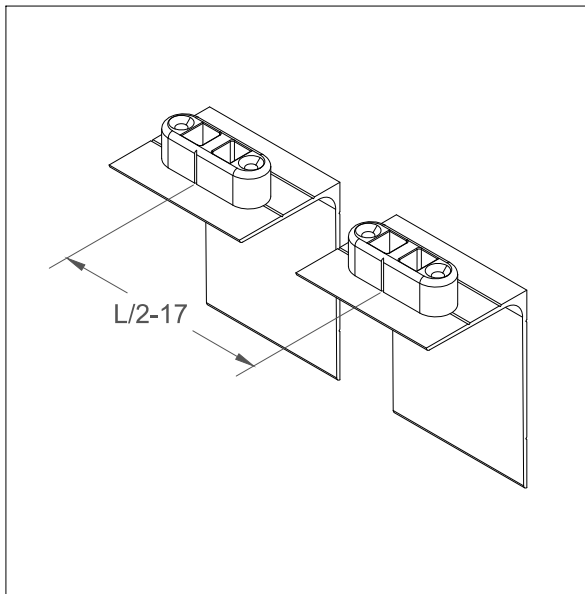
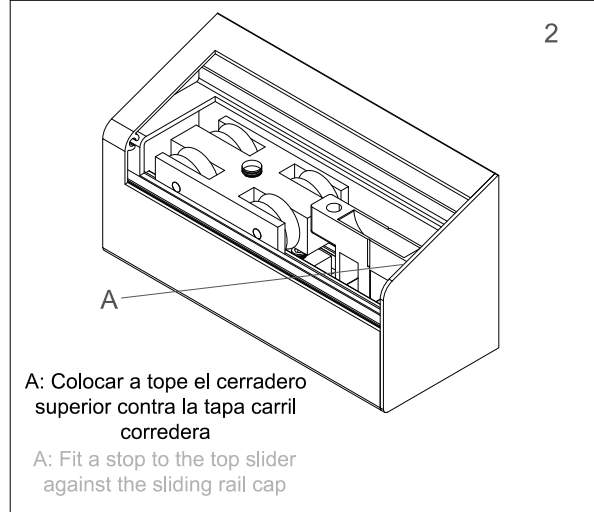
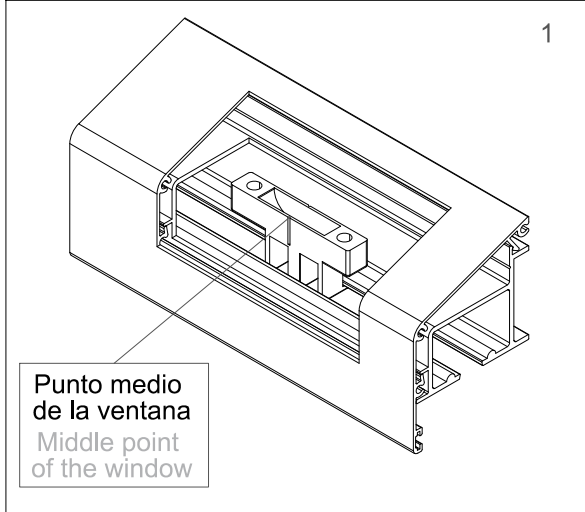

ENSAMBLAJE HOJA CON CARRIL SUPERIOR EN TAMIZ EXTERIOR
SASH ASSEMBLY WITH UPPER RAIL IN OUTWARD TAMIZ

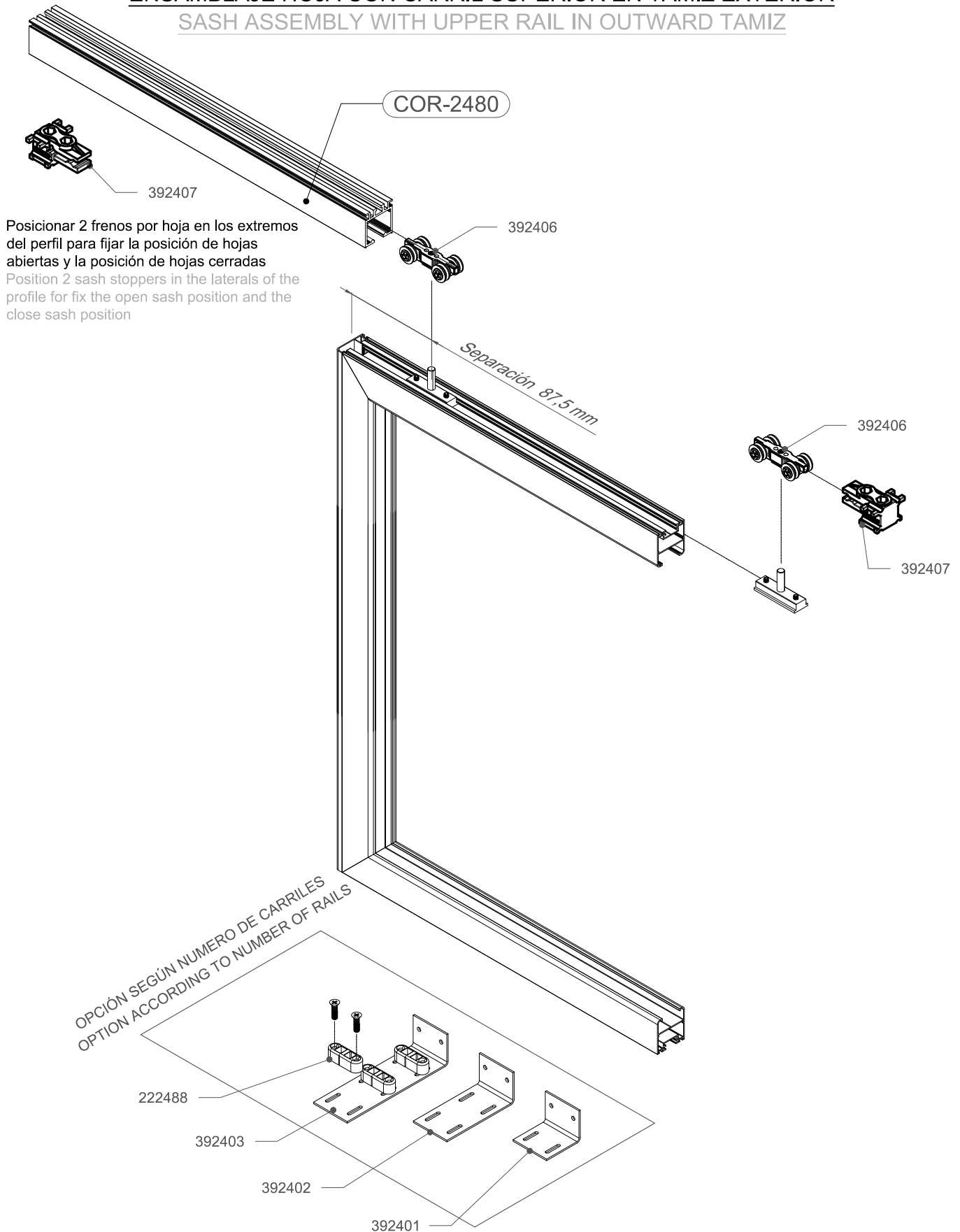

MECANIZADO PASO CERRADERO
LOCK PASSAGE FABRICATION

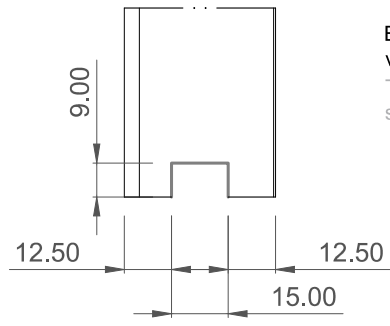
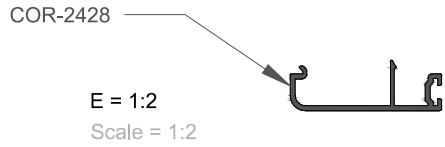

Este mecanizado sólo ha de realizarse en
ventanas correderas de 1 hoja
This fabrication is only to be carried out on single
sash sliding windows

